



Renault lungo is a level 4 semi-autonomous vehicle. It is designed to help people who commute in a very long distance.

IUNGO

INTERCITY COMMUTER CONCEPT

DEMOGRAPHIC



INTER CITY / STATE COMMUTERS

The goal for this project is to provide a better solution for the commuters who commute long distance. These trips usually above 4 hours one way everyweek. I have identified the mayjor reasons in the following.



TRAVEL ON BUSINESS

This represents the group of people who need to travel between companies for meetings, field works, and etc.



THE SUPER COMMUTERS

A “super-commuter” is someone who monnutes from one metropolitan area to another. In Paris, between 2010 and 2017, the number of super commuters grew 44%.



One of the major ways to commute in long distance is to take rail way train. However, many states suffer from poor rail way infrastructure.



Inconvenient.
Many describe as “one security check to another.” Flight delay.



Flexible, “hop in and go.” Get your from door to door. Cheaper than air plane. Privacy
Already established freeway infrastructure.

BUYER PROFILE



Alex Miller

He is 37 years old, married, working for an IT company with an affluent income. His company has recently moved from Toulouse to Paris. He decides to have a second home in Paris so that he can commute between Toulouse and Paris. Alex spends his weekend with his family in Toulouse. For the weekdays, he has to stay in Paris.

Motivations

Alex and his family were living in a nice community in Toulouse. His wife also works locally. A year ago, the IT company he works for had been relocated to Paris, but he does not want to move his family to a new community in Paris. Therefore, he decides to commute every week. The first couple of months, Alex chose to commute on airplanes. Sooner, he found out that it is better to **drive** himself home because it is more **flexible** and **convenient**.

CONTRIBUTING FACTORS :

- MARRIED
- WORKING IN PARIS
- FAMILY LIVES IN TOULOUSE
- COMMUTE BETWEEN TLS AND PAR IN WEEKENDS
- IMAGE SEEKER



DRIVING FOR LAST MILE

PREPARE FOR WORK

SLEEPING

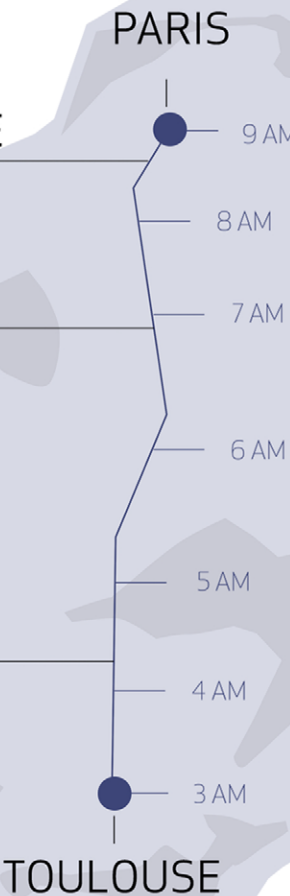



Alex and his family lives in a nice community in Toulouse. He works for a IT company in Downtown, and his wife works locally. They love to spend their time together for shopping, hiking, attending to musical concert, and etc

LIVING IN TOULOUSE >

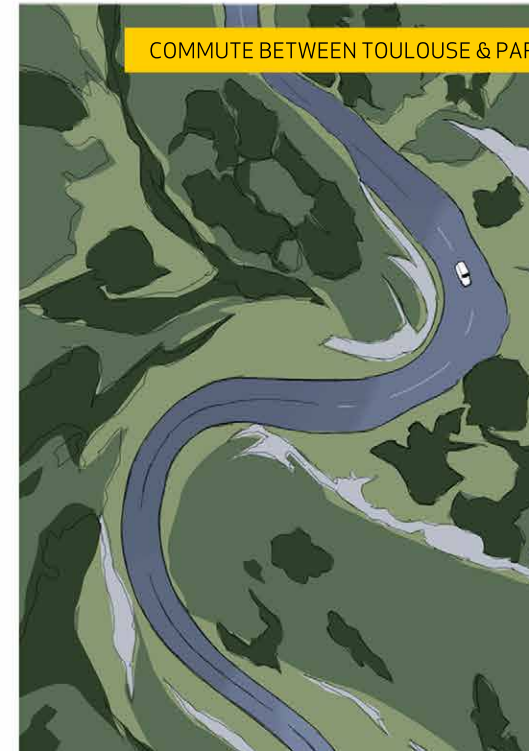

COMMUTE BETWEEN TOULOUSE & PARIS >



Alex wakes up 3 am monday on his bed. It is time for him to get up and start his weekly commute to Paris. He needs to get in his car in order to make it to his work, and his office is almost four hundred miles away. After abraoding his vehicle, Alex set his destination, and command it into autonomous mode. Then he switched from driver seat to passenger lounge, and he will continue to sleep.

Alex wakes up inside his vehicle around 7 am. And he is arriving his destination. He feels energized, and he is ready for a new day. Now he is browsing through website and checking E-mails.

In Paris, the traffic can be bad especially during the peak hours. In order to navigate through the traffic effectively, Alex decides to take over and drive the last a few miles to his final destination.

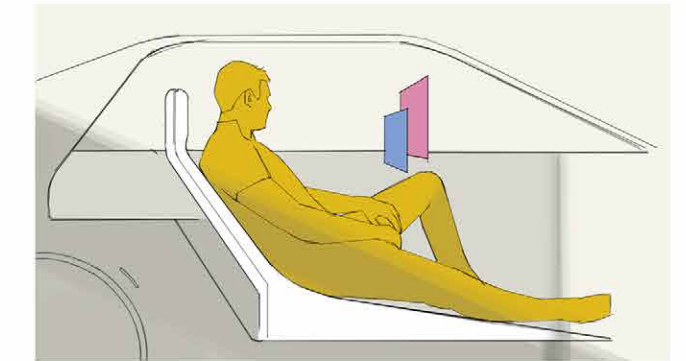

COMPANY RELOCATING TO PARIS >

One day, during a company meeting, the board decides to relocate the company from Toulouse to Paris. Alex is in a dilemma. He neither want to move his family to Paris nor lose his job. He can have a second home in Piras while his wife stays in Toulouse.

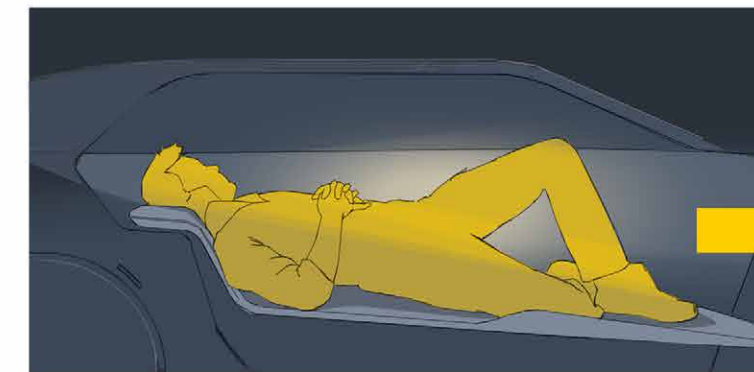

8 AM >

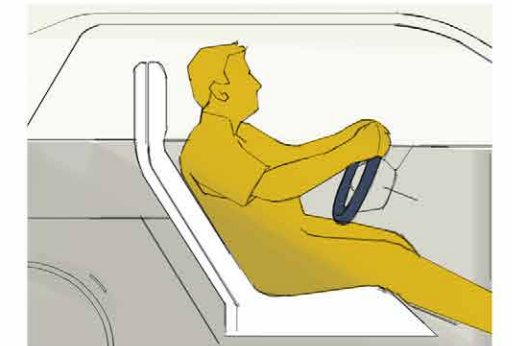

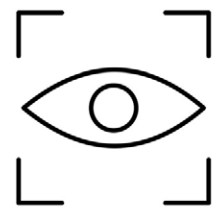

VISUAL INSPIRATIONS

Alex is an observer. He enjoys to observe the nature and beautiful designs. He has a collection of furnitures and fashions.

TANGIBLE



ABSTRACT

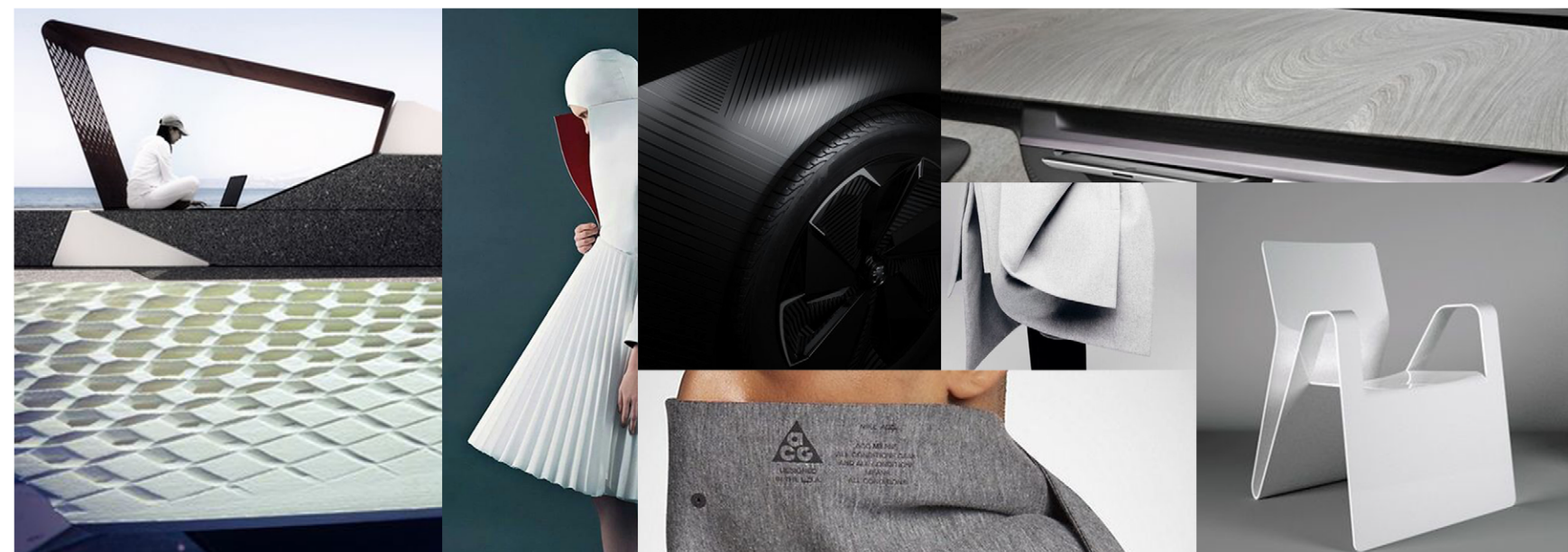

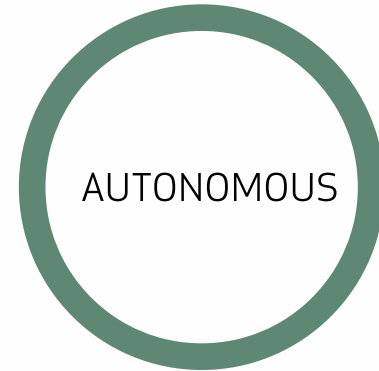

DRIVING DOMINANT

DIRECTION



According to the story behind the concept, Alex will be mostly driving this vehicle on the freeway. Instead of simply setting the vehicle on autonomous mode and then sleeping in the vehicle, or browsing the Internet, why don't make driving more fun. In this direction I will be focusing more on how to build a better driving experience, and consider autonomy as a supporting function.

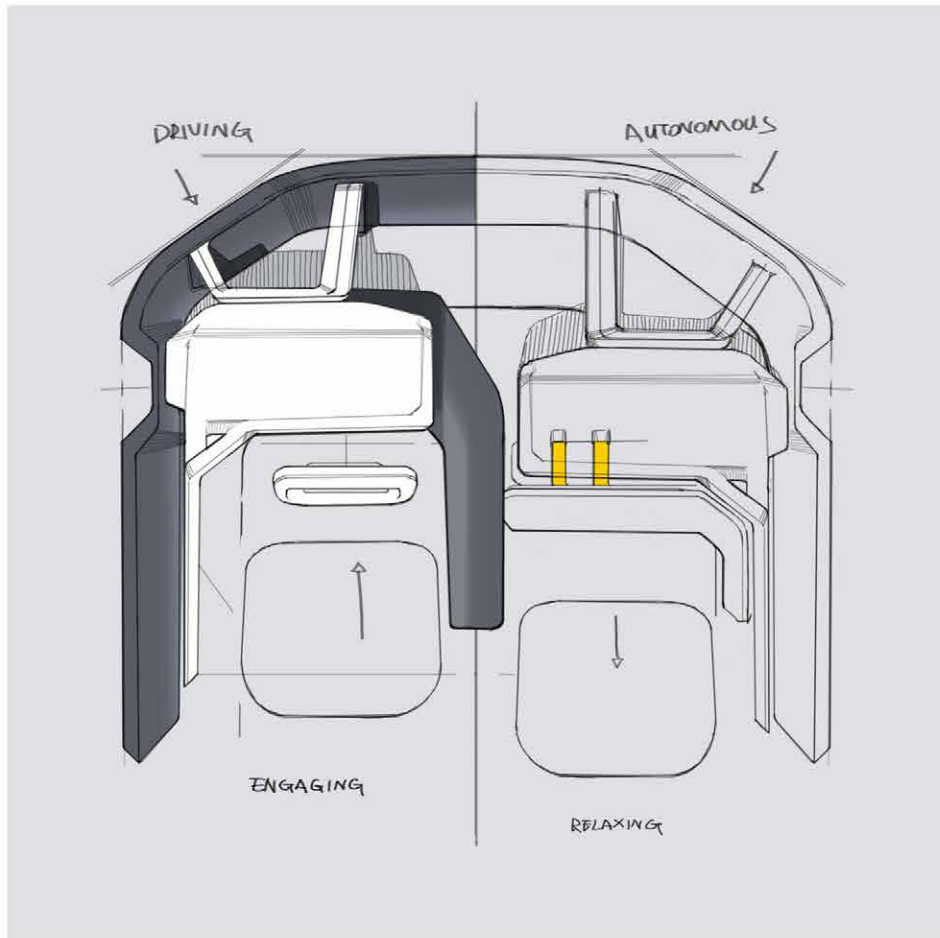

a.

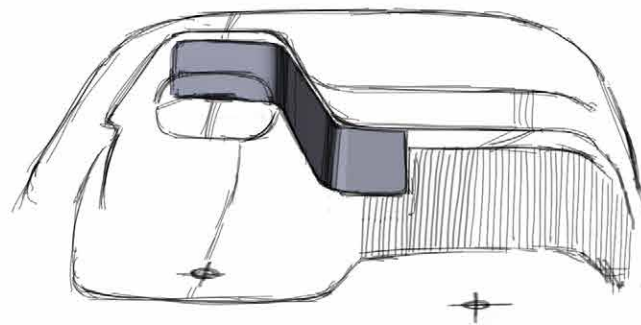

b.

a. Independent

The idea is to divide the interior space to Driving Zone and Autonomous Zone. Each area is independent to each other.

b. Engaging

Driver centric design. On driving mode, driver's seat will move forward. Steering wheel and screen approach and welcome the driver.

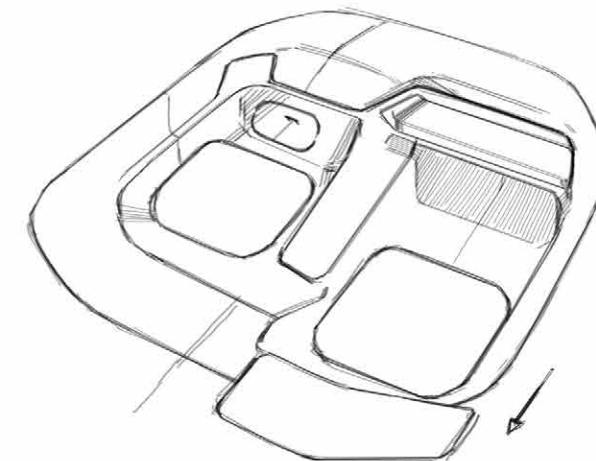
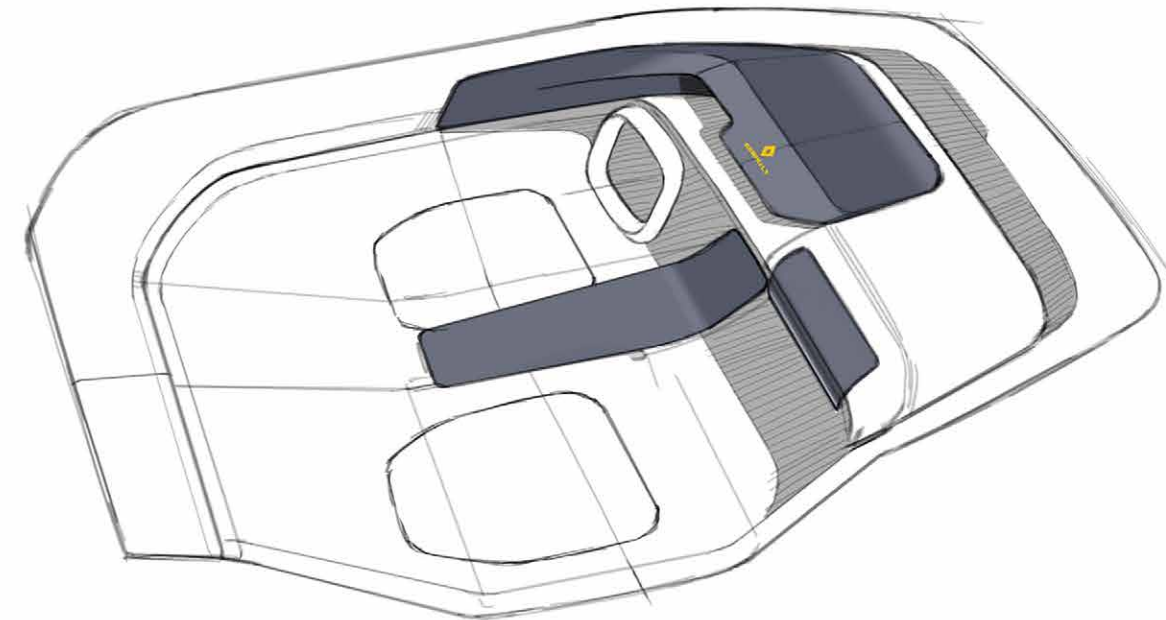

a.

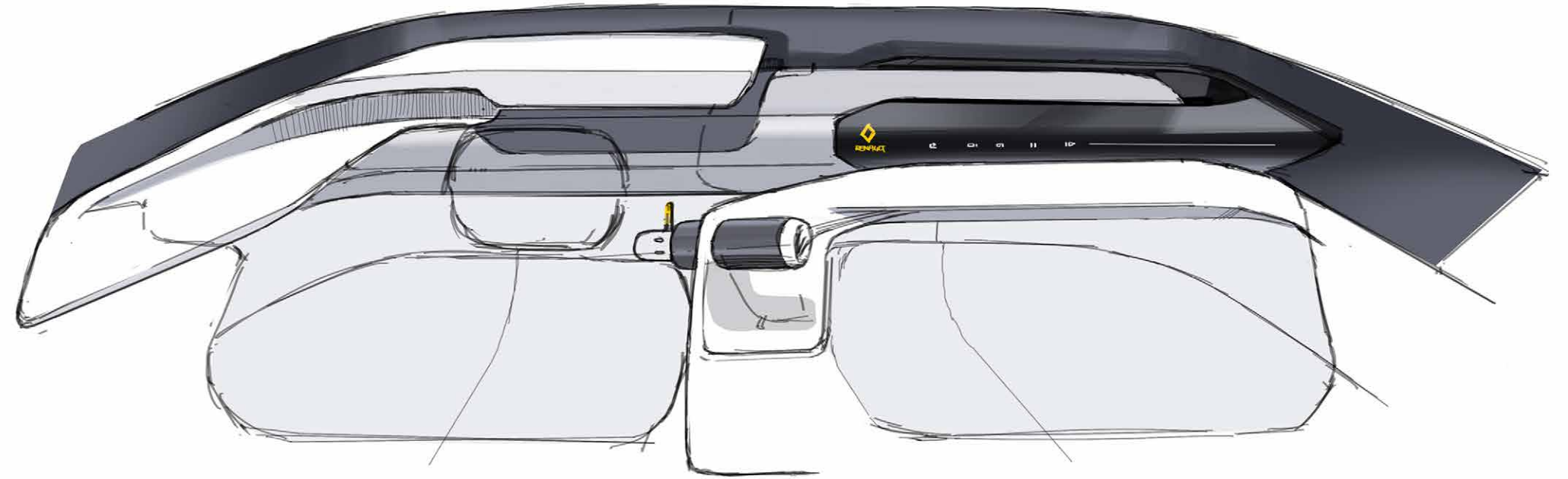
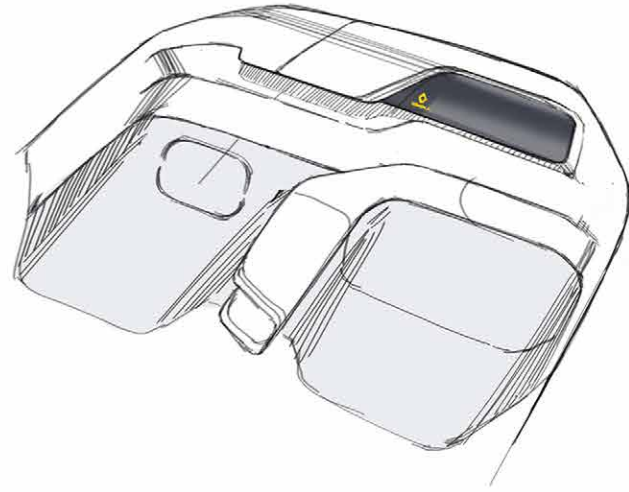
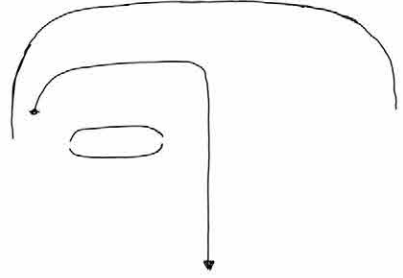

b.

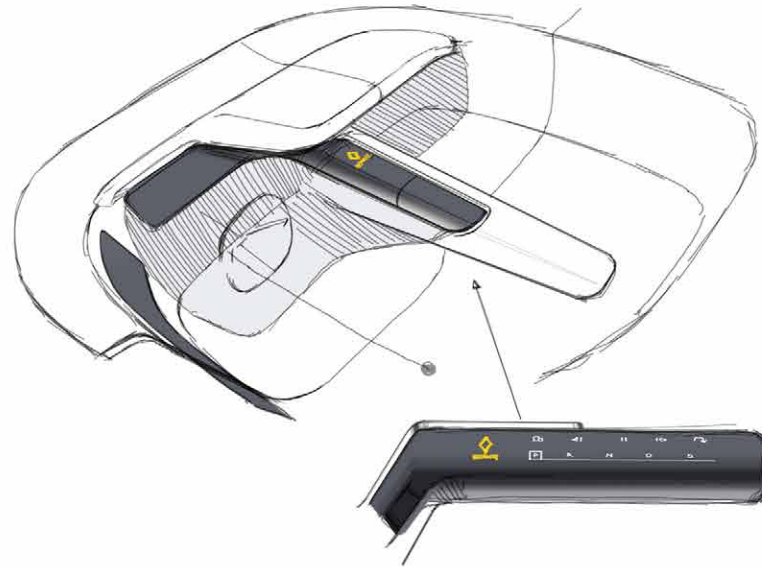
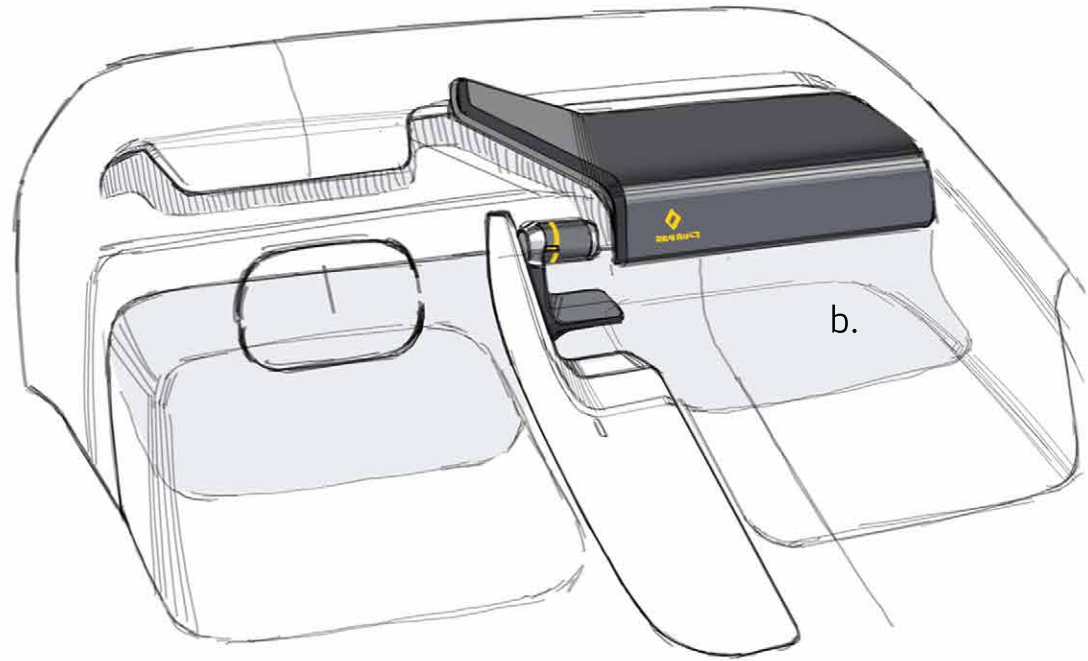

a. Driver-centric design

In order to enhance driving experience, the driver needs to feel the excitement of driving.

b. Physical controls

Provide switches / shifter that the driver can pull or grab to enhance driving.

a. Shifter design

Squeeze push or pull it to shift gears.

b. Repurposed IP

Thanks to the car autonomy, vehicles might not need airbags anymore. Which opens up opportunities for design. Instead of having a traditional IP on the passenger side, it can be turned in to a bigger screen for entertainment.

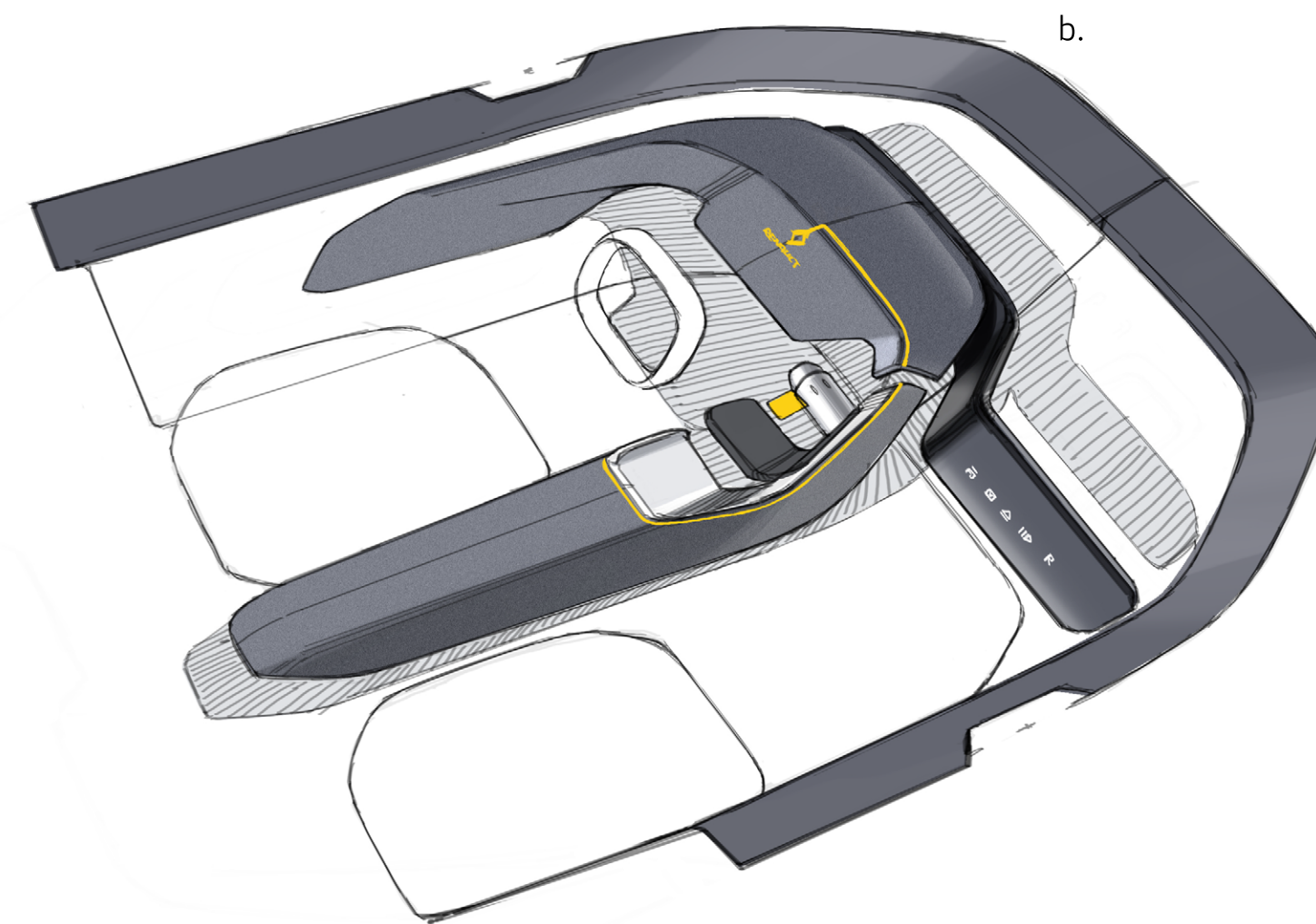
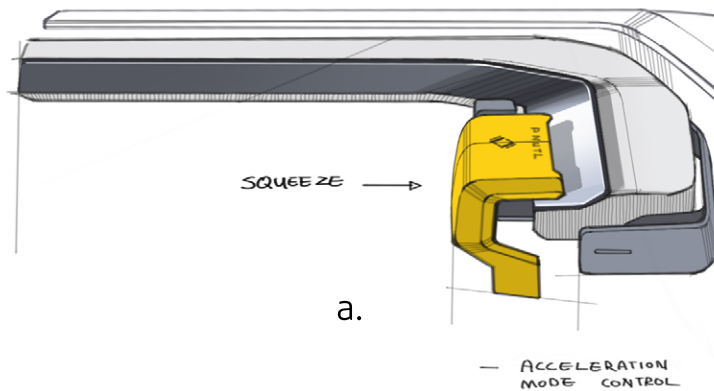
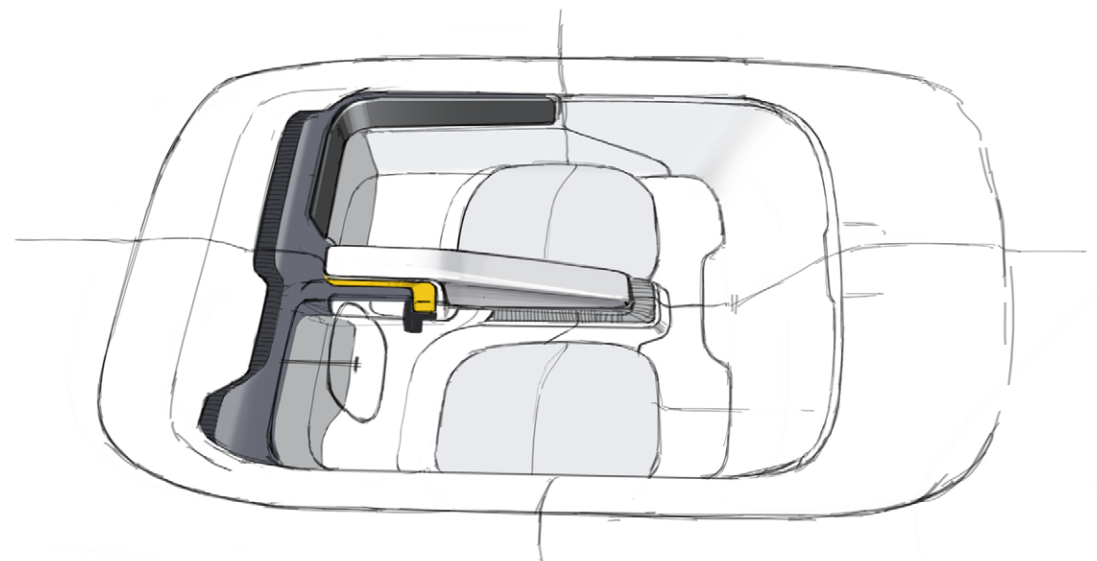
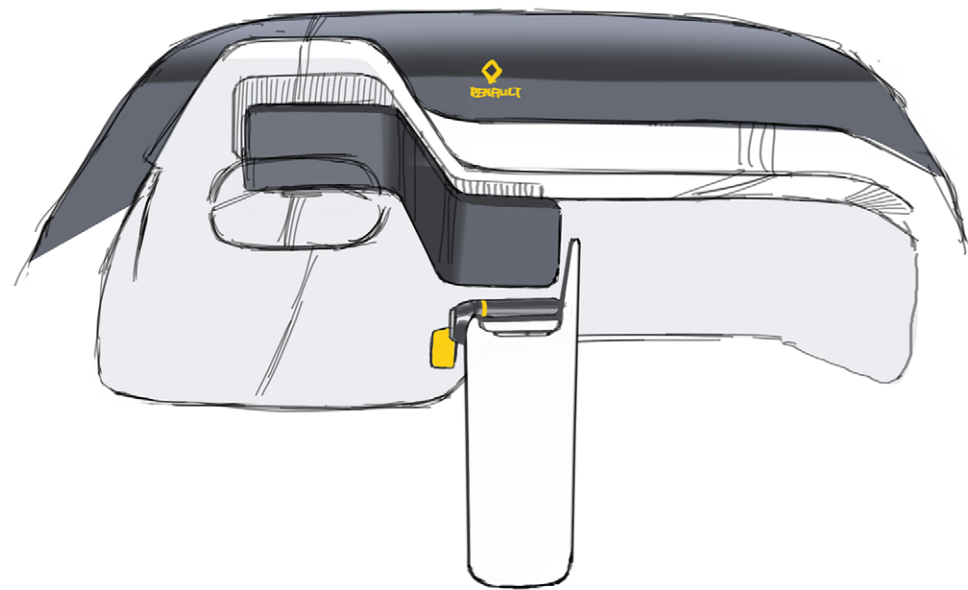

DIRECTION A REFINEMENT

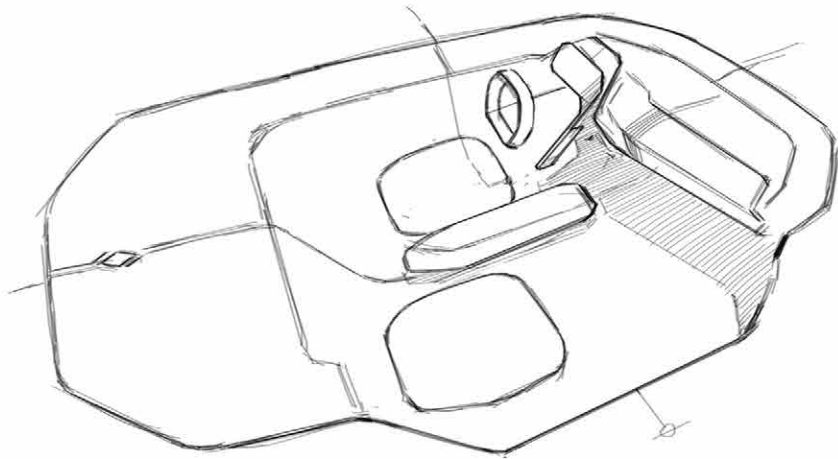
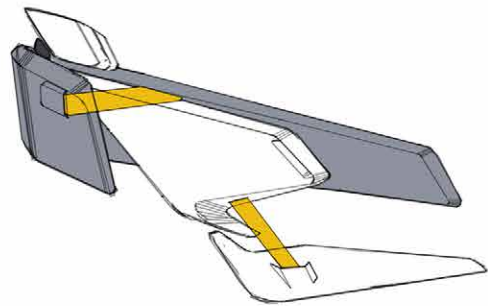
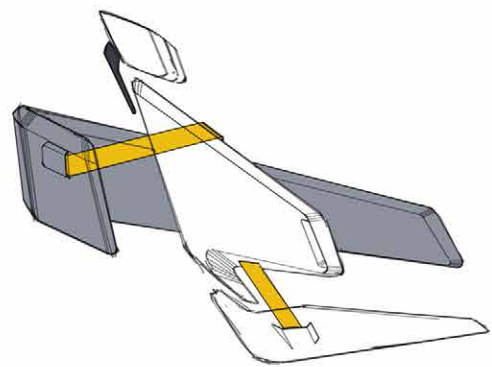
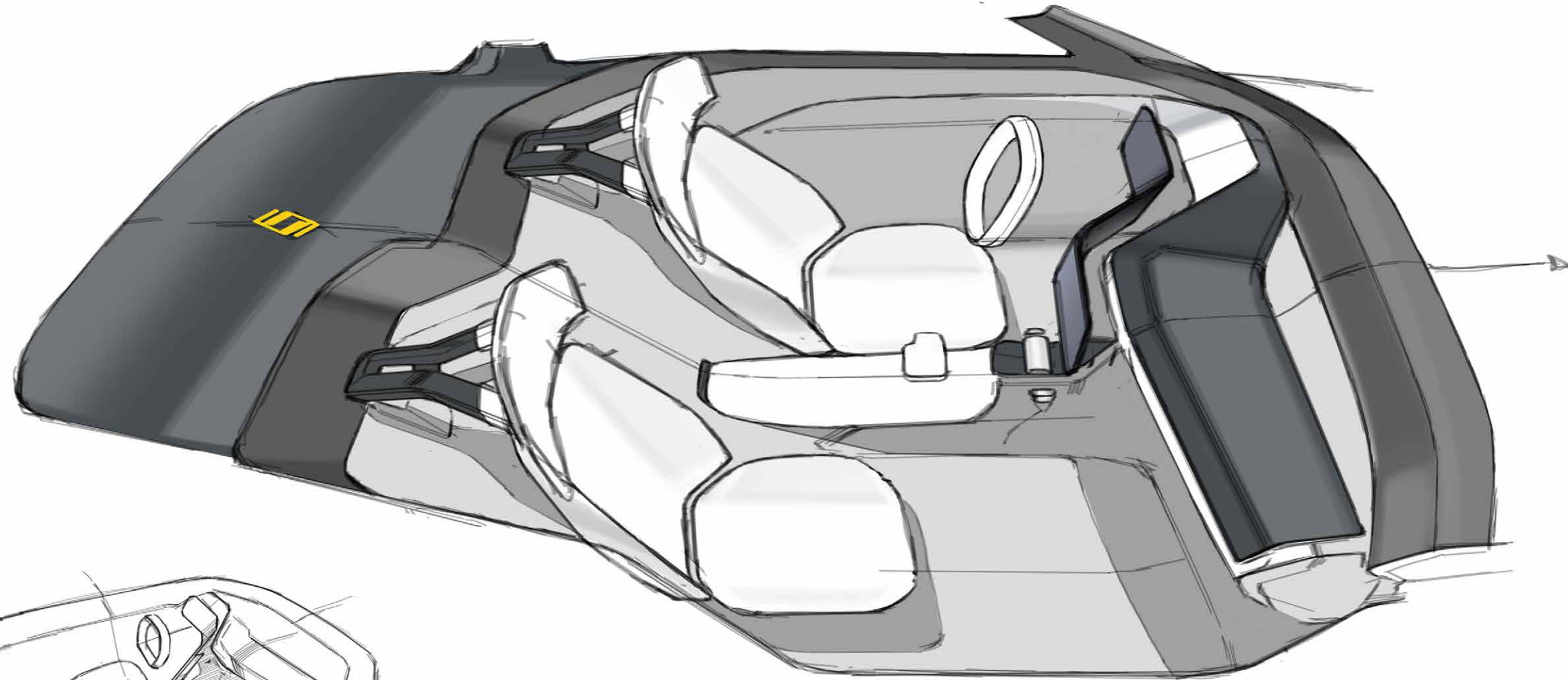
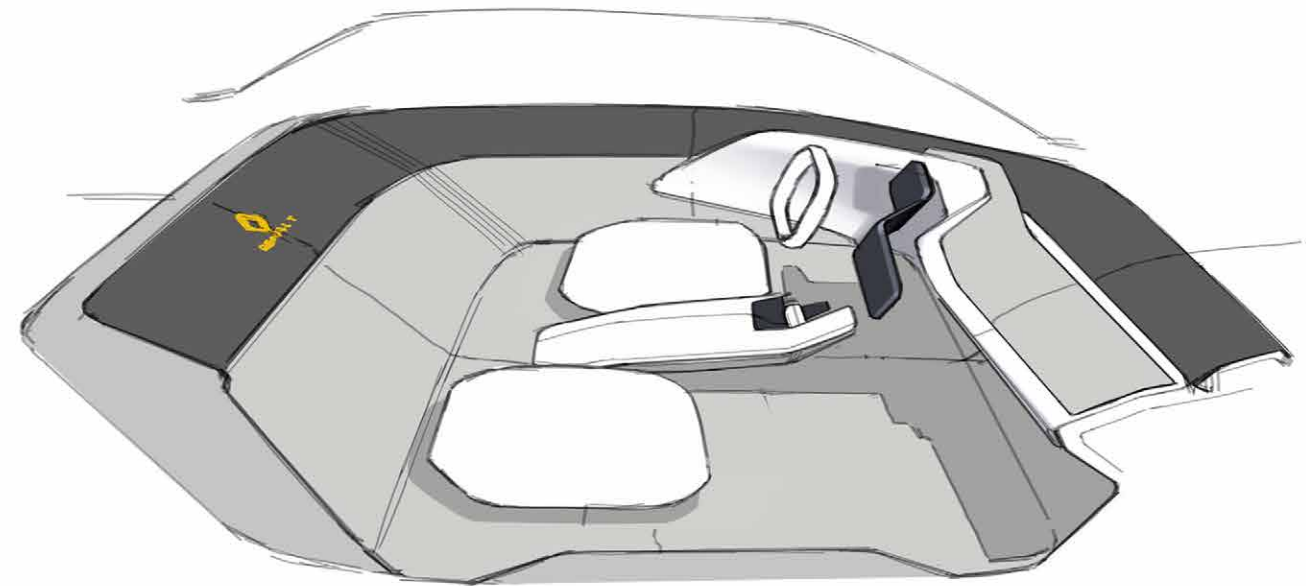

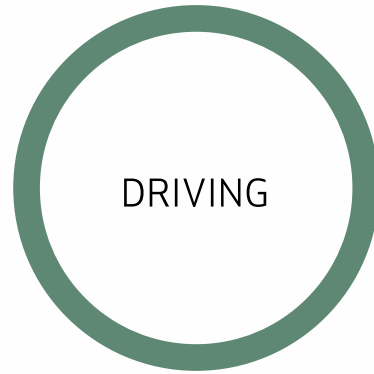

=

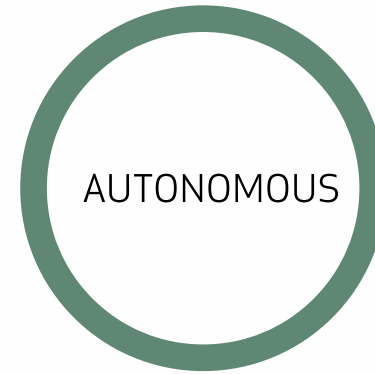

BALANCED

DIRECTION

B

In this direction, I will design for the idea "autonomous is equally important as driving." Alex (the target buyer) spends his weekends with his wife in Toulouse. I want the time they spend in the vehicle to be an experience that bring the family together.

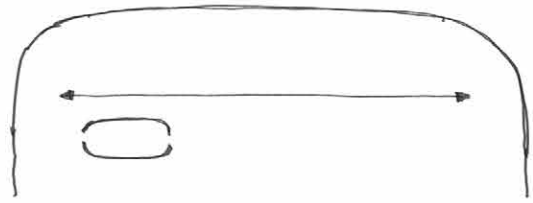

a. Lounge + seat

Sacrifice center console for more space for people. During autonomous mode, seat can be turned into lounge.

b. Integrated

Integrate two seat together, this design reflects the idea of bringing two people together.

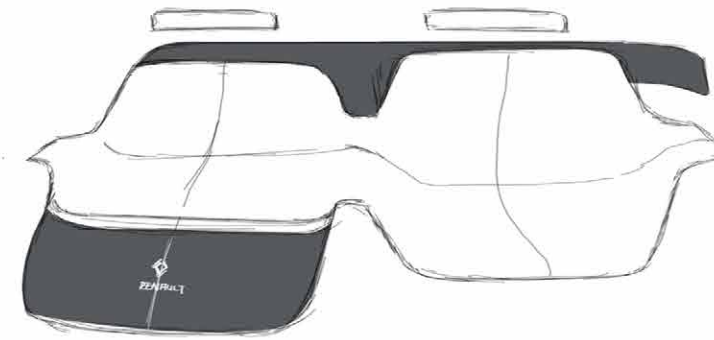
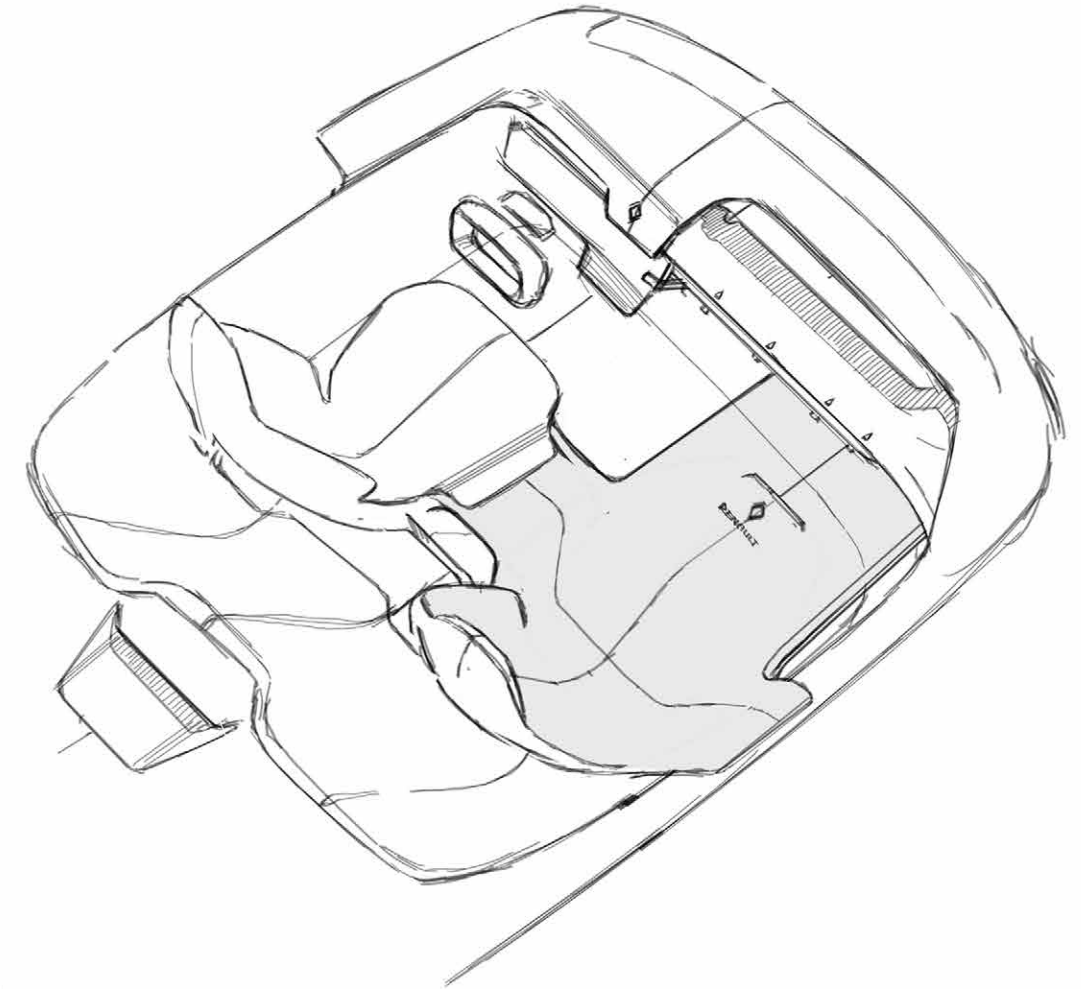

b.

DIRECTION B KEY SKETCH

a. Seat to lounge

Seat can be converted into a lounge while travelling in autonomous mode. Maximizing comfort

b. Mode switches

Incorporate physical switch with screen, provides a reference point for your hand.

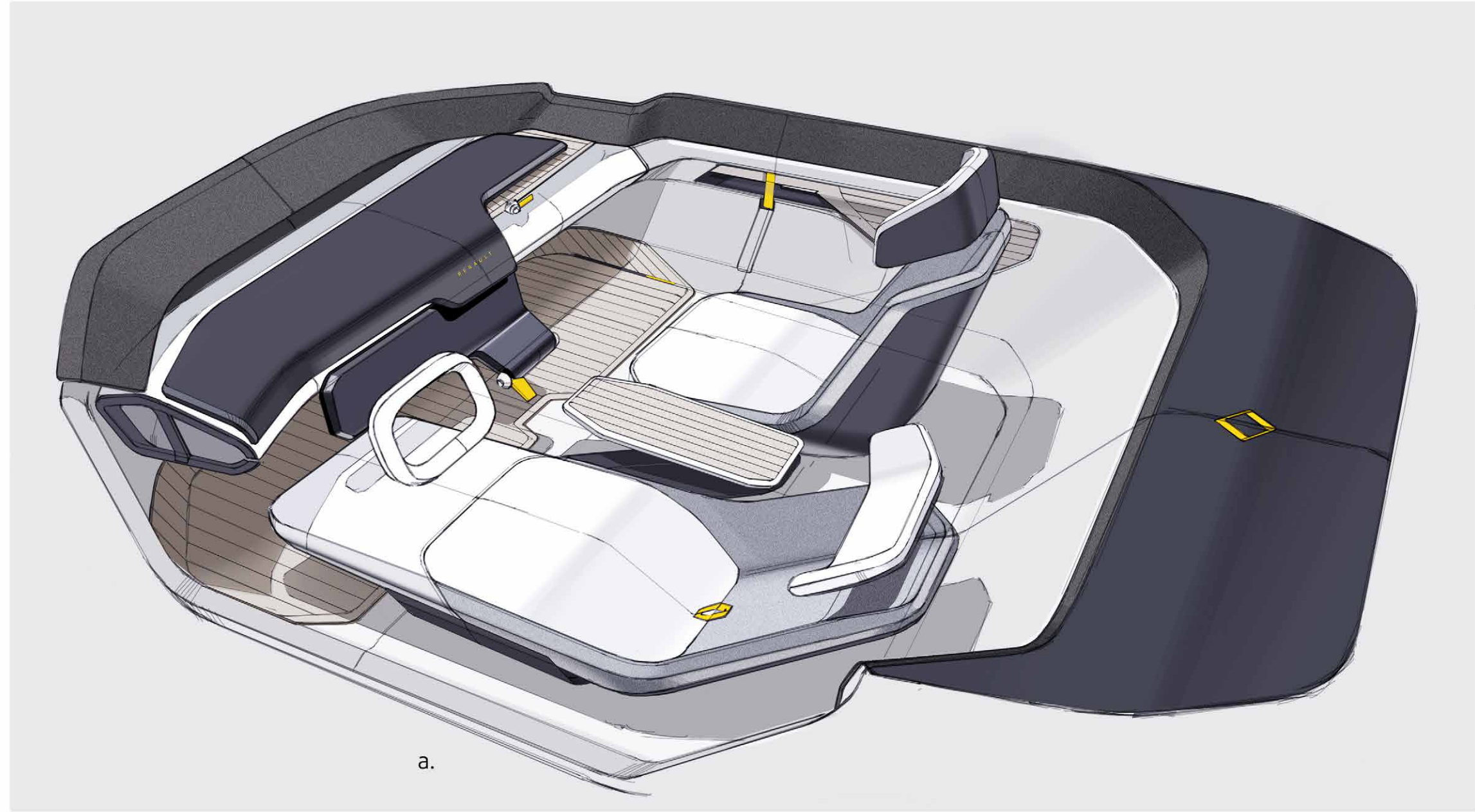
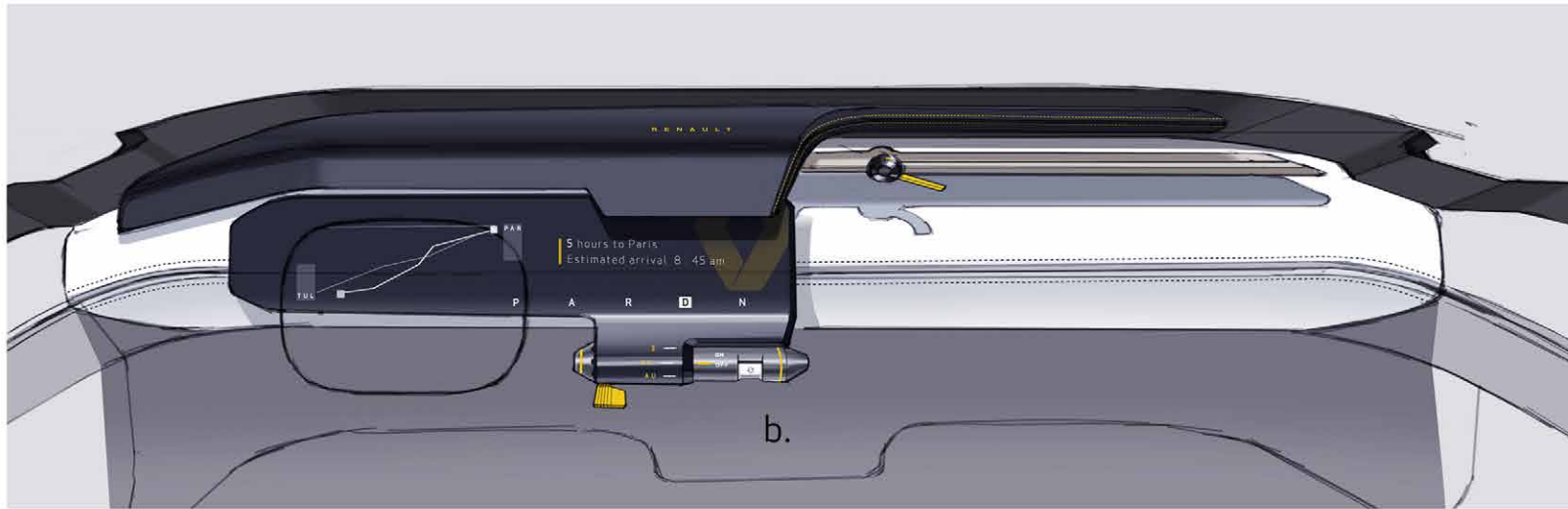

DIRECTION B IDEATION

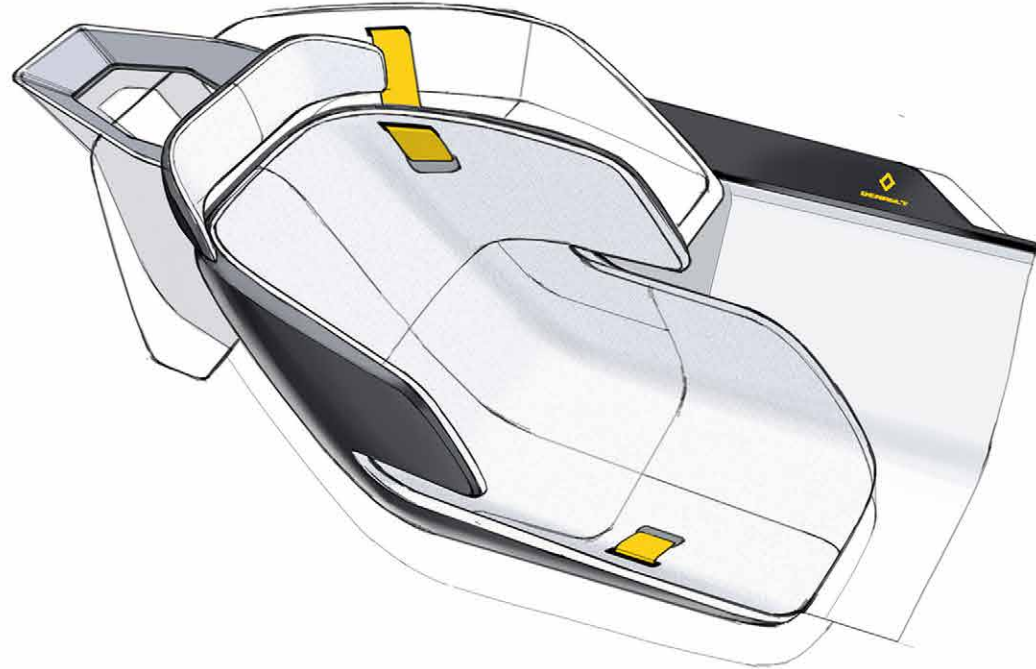
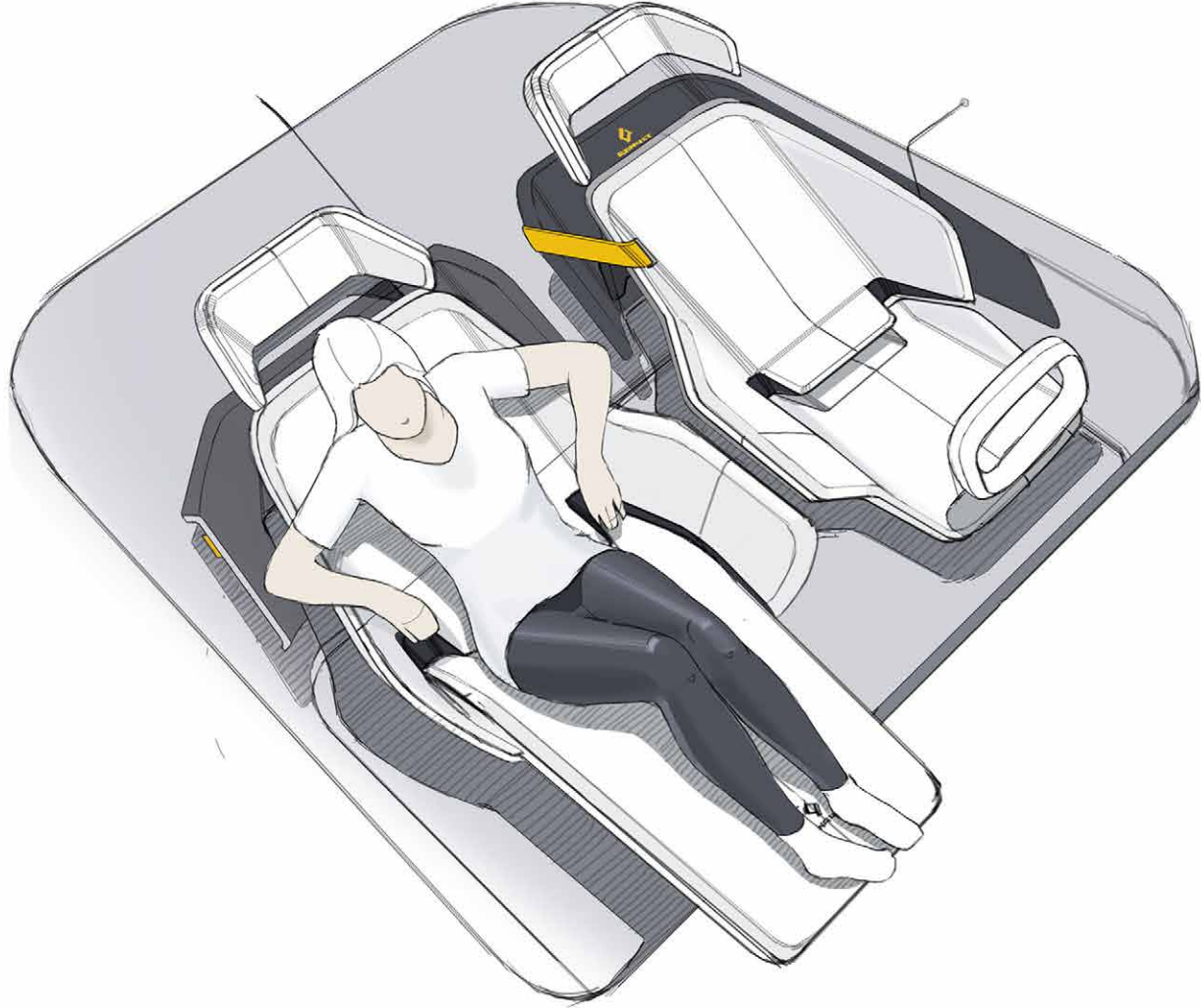

- a. Conform
Sporty, comfortable, and conforms the body.
- b. Minimal
Less confined. Visually looks clean.

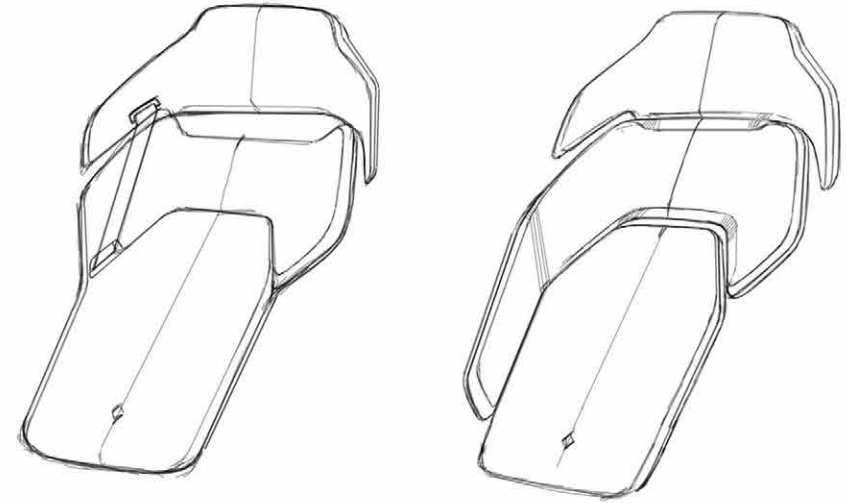

DIRECTION B IDEATION

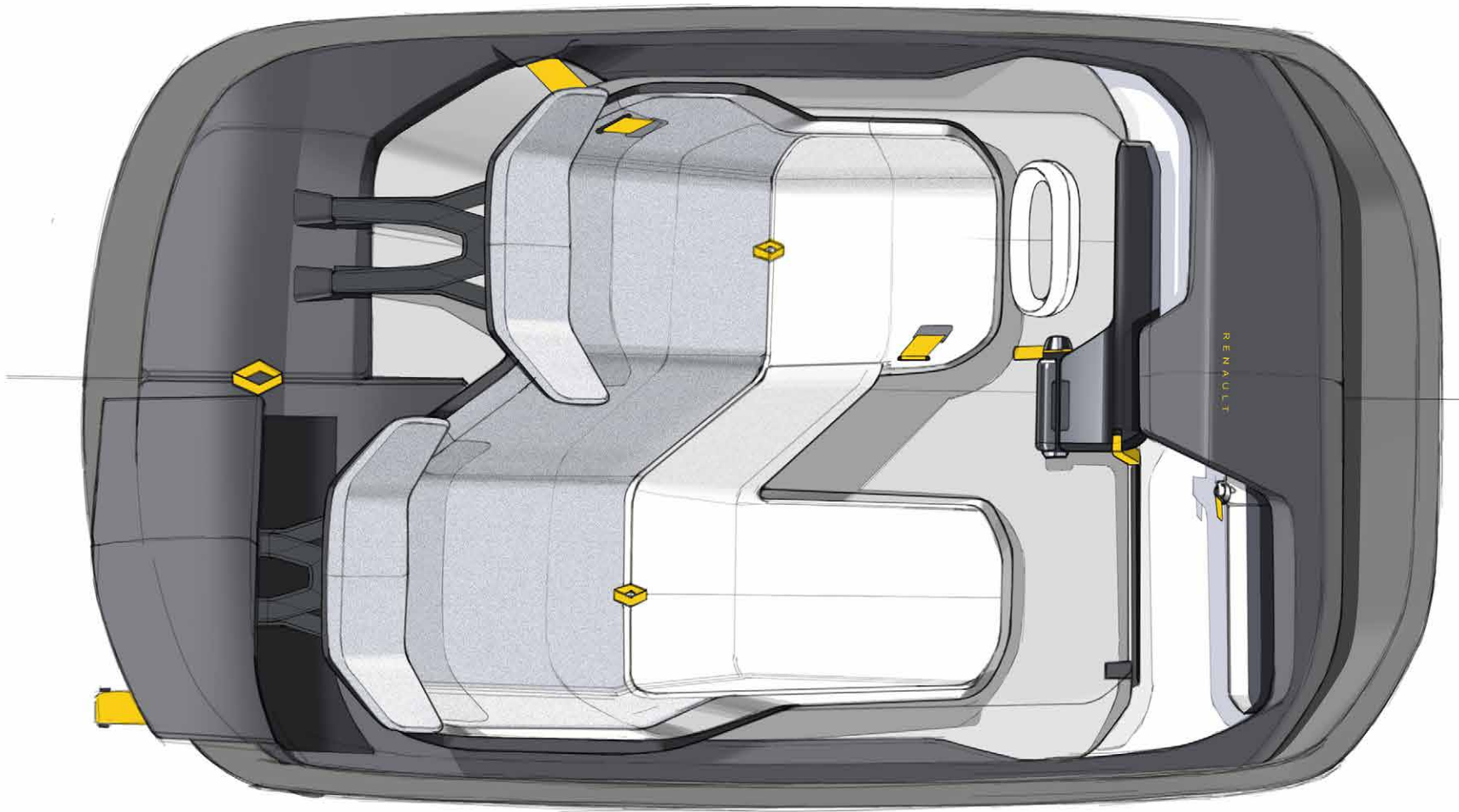

a. Driving mode

The display is all the way to the driver's side.

b. Theater mode

When there are two people on the vehicle. Setting display to the middle, and enjoy a movie.

b. Work-station mode

During the commute, passenger side can be turned into a personal work station.

a.

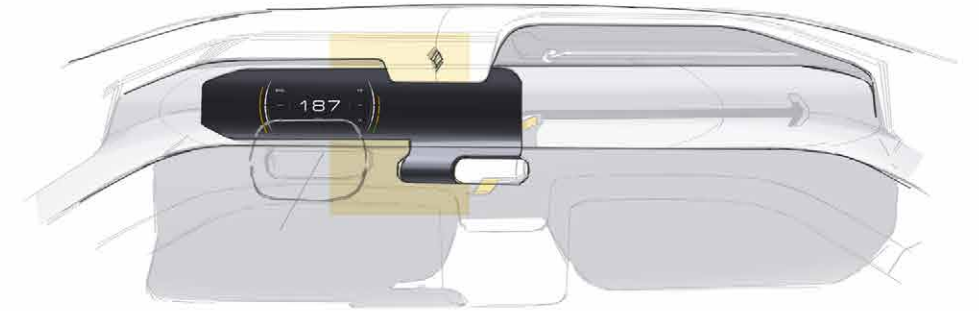

b.

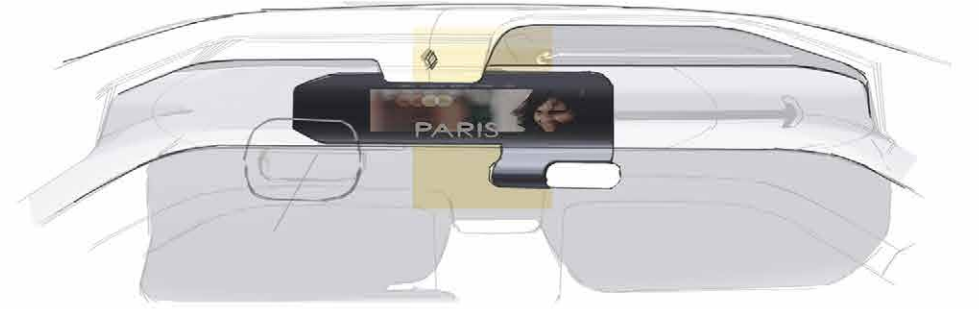

c.

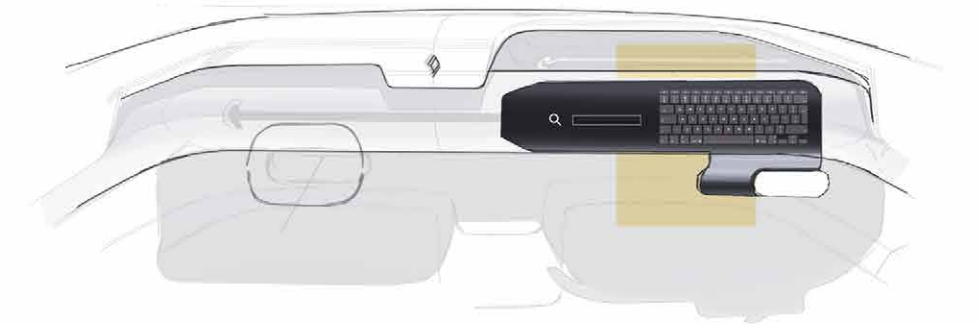

a. Wine storage & Ice box

Nothing is better than having a glass of wine during a long journey.

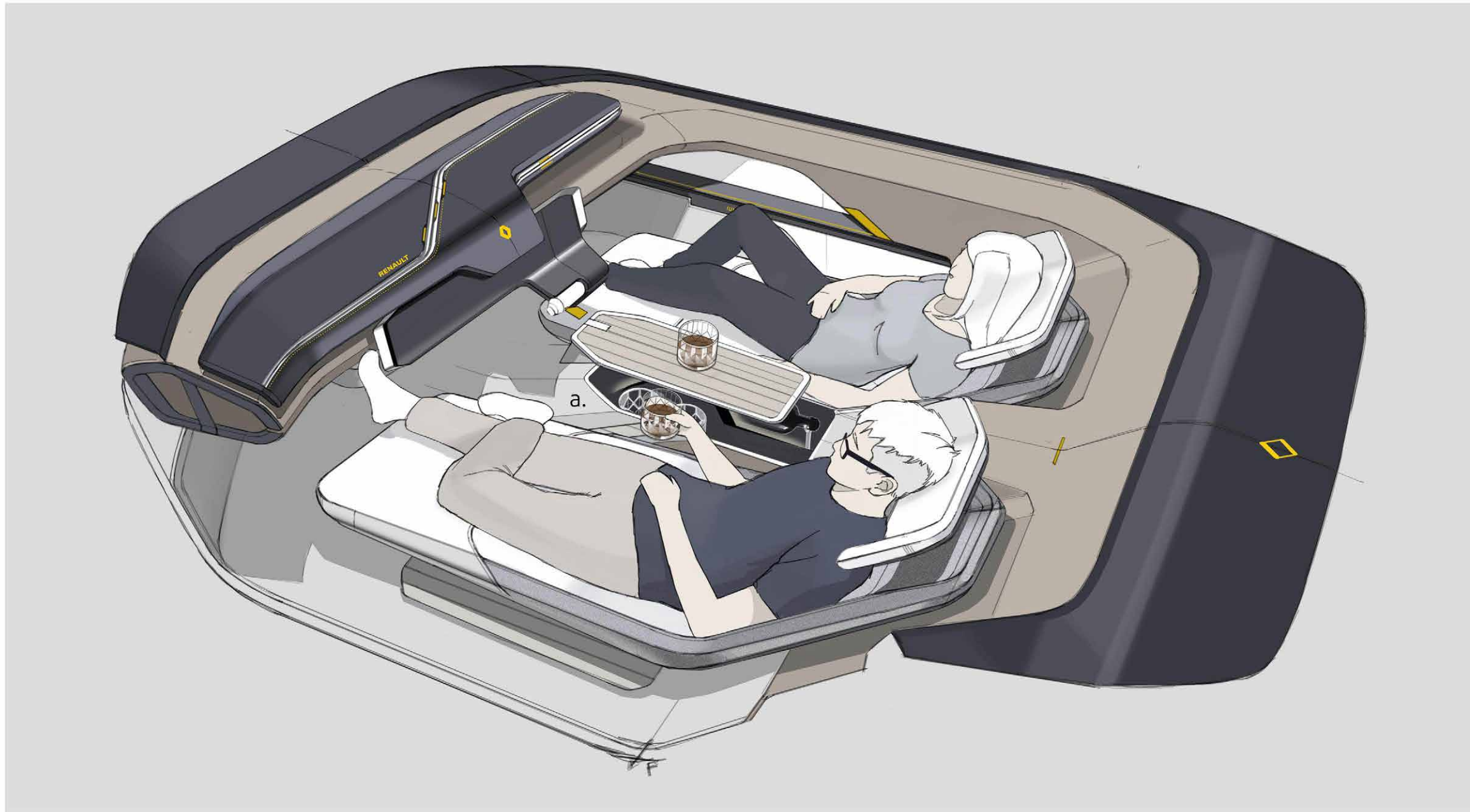
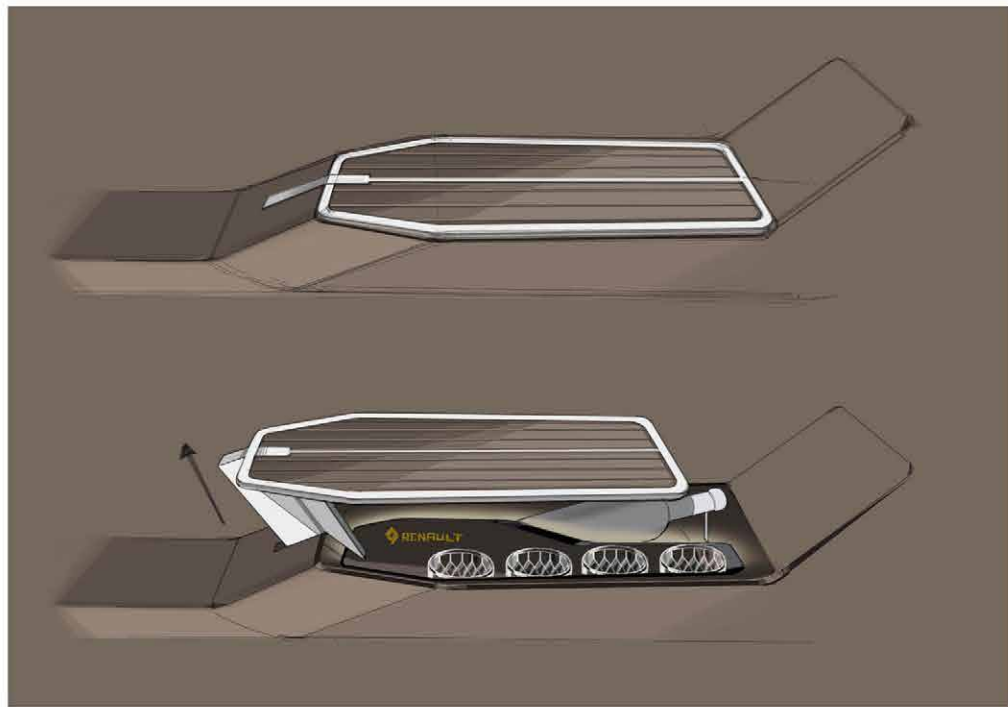

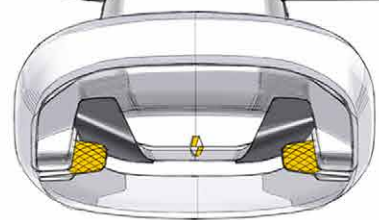

a. Interior = Exterior

"inside is a part of outside." Part of the interior (soft material) stretches out and become exterior.

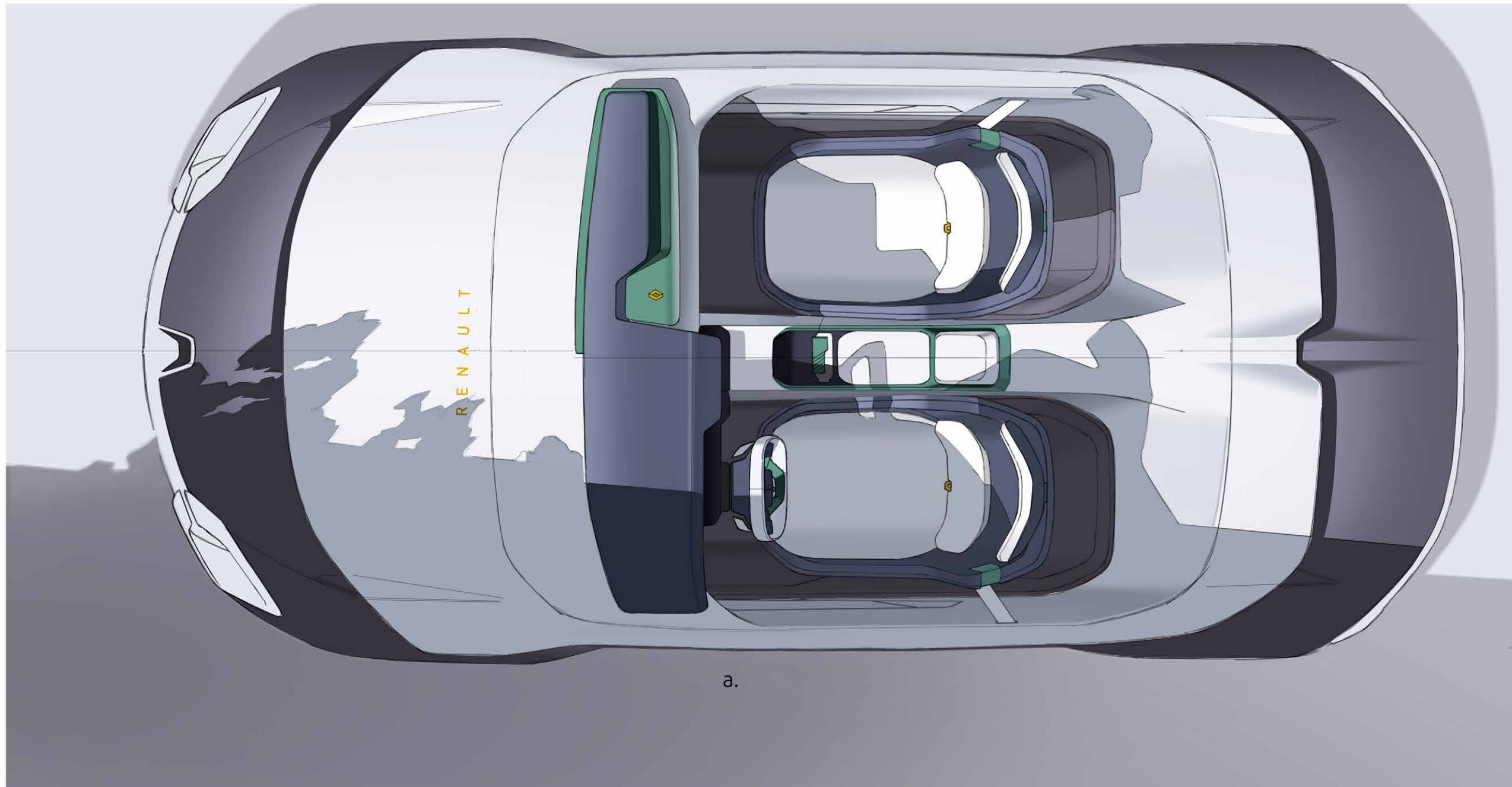
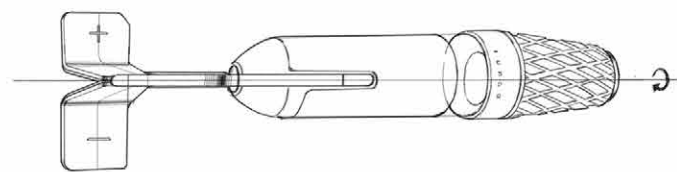
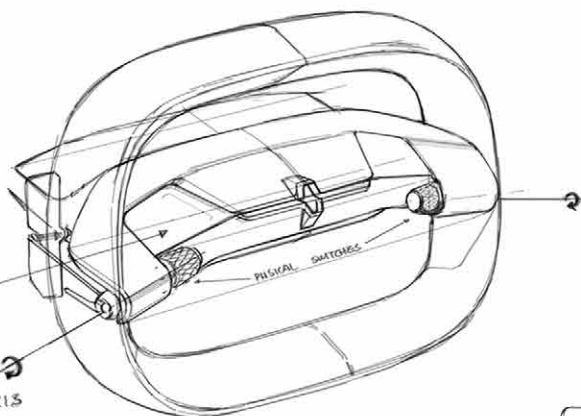



RENAULT

5 hours to Paris
Estimated arrival 8:45 am

MAX

D MODE

YOU HAVE 1 UNREAD
MESSAGE

